

MOTOR TYP 490

Engine Type 490 '86

80cc - MX

TECHNISCHE DATEN

MOTOR	80/I
BAUART	FLÜSSIGKEITSGEKÜHLTER EINZYLINDER - ZWEITAKT - OTTOMOTOR
HUBRAUM	78,1 cm ³
BOHRUNG/HUB	46,5/46 mm
LEISTUNG MAX.	17,3 kW(23,5 DIN PS)
NENNDREHZAHL	12.000/min
KRAFTSTOFF	SUPERKRAFTSTOFF ROZ 98, MIT ZWEITAKTÖL GEMISCHT
MISCHUNGSVERHÄLTNIS	1:40 BEI VERWENDUNG VON HOCHWERTIGEM 2-TAKT-MOTORÖL IM ZWEIFELSFALL SETZEN SIE SICH BITTE MIT IHREM IMPORTEUR IN VERBINDUNG ODER MISCHEN SIE VORSICHTSHALBER 1:30
●MASS "X"	0,40 - 0,45 mm
ZÜNDZEITPUNKT	0,75-0,85 mm (13,2°-14°) v.OT
ZÜNDKERZE	BOSCH W 07 CS
ELEKTRODENABSTAND	0,6 mm
GETRIEBESCHMIERUNG	0,55 LITER, MISCHUNGSVERHÄLTNIS 2:1 - FROSTSCHUTZMITTEL: WASSER
KÜHLFLÜSSIGKEIT	0,3 l HYPOIDÖL SAE 80
ZÜNDANLAGE	KONTAKTLOS GESTEUERTE THYRISTOR-ZÜNDANLAGE

●DAS MASS "X" IST DER ABSTAND DER KOLBENOBERRANTE ZUR ZYLINDEROBERRANTE, GEMESSEN BLI OT-STELLUNG UND NIEDERGESPANNTEM ZYLINDER.

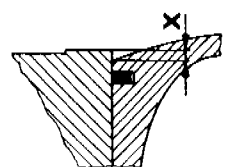

Technical Data

Engine	80/I
Design	Liquid- cooled single-cylinder two - stroke engine
Piston displacement	78,1 cc
Bore/stroke	46,5/46 mm
Performance max.	17,3 kW(23,5 DIN-PS)
rpm at max. HP	12.000/min
Fuel	SUPER fuel, research octane no 98,mixed with two-stroke oil
Oil/gasoline ratio	1:40 when using 2-stroke competition oil. When in doubt, please contact your importeur or use 1:30 mix ratio to be on the safe side.
●Dimension "x"	0,40 - 0,45 mm
Ignition timing	0,75-0,85 mm (13,2°-14°) BTDC
Spark plug	Bosch W 07 CS
Electrode gap	0,6 mm
Gear lubrication	0,3 l hypoid oil SAE 80
Coolant	0,55 litres mixture 2:1 of anti-freeze and water
Ignition system	solid-state thyristor ignition system

●Dimension "x" is the difference between the top edge and the cylinder top edge measured with piston at top dead centre and with cylinder bolted down.

GETRIEBEÜBERSETZUNGEN		Gear box ratios	
PRIMÄRÜBERSETZUNG	23:75	Primary Ratio	
1.GANG	13:37	1st gear	
2.GANG	16:34	2nd gear	
3.GANG	18:31	3rd gear	
4.GANG	21:30	4th gear	
5.GANG	23:28	5th gear	
6.GANG	24:26	6th gear	
ORIGINAL-ÜBERSETZUNG HINTERRAD	14:50	Original Final Drive Ratio	
LIEFERBARE KETTENRÄDER VORNE	13,14,15	Available Chain Drive Sprockets	
LIEFERBARE KETTENRÄDER HINTEN	48,50,52	Available Final Drive Sprockets	

VERGASER- GRUNDEINSTELLUNG		Basic carburettor setting	
VERGASERTYPE	PHSB 35 MS	carburettor type	
HAUPTDÜSE	168	Main jet	
NADELDÜSE	2.68 BH	Needle jet	
LEERLAUFDÜSE	55	Idling jet	
DÜSENNADEL	K 36	Jet needle	
NADELPOSITION	3. VON OBEN / 3rd from top	Needle position	
LUFTRREGULIER- SCHRAUBE OFFEN	1 1/2 UMDR./turn	Pilot air adjusting screw open	
SCHIEBER	40	Throttle valve	
STARTDÜSE	70	Starting jet	

TOLERANZEN - EINBAUSPIELE		Tolerances and Fitting clearances	
KOLBENEINBAUSPIEL	0,04 mm	piston fitting clearances	
KOLBENRING - STOSSPIEL	0,1-0,3 mm	piston ring end gap	
PLEUELLAGER-RADIAL	0,021-0,032 mm	connecting rod bearing- radial clearances	
GETRIEBEWELLEN-AXIALSPIEL	0,1-0,2 mm	transmission shaft end float	
KUPPLUNGSDRUCKFEDERN-LÄNGE	2,4 Ø - 27 mm	clutch springs-lenght	

DICHTUNGSSTÄRKEN		Gasket Thicknesses	
MOTORGEHÄUSE	0,3 mm	crank case	
KUPPLUNGSDECKEL	0,3 mm	clutch cover	
WASSERPUMPENDECKEL	0,3 mm	water pump cover	
ZÜNDUNGSDECKEL	0,3 mm	ignition cover	
ZYLINDERFUSSDICHTUNG	NACH BEDARF/as required (0,05/0,2/0,3/0,5/1,0mm)	cylinder bottom gasket	
ZYLINDERKOPFDICHTUNG	1 mm	cylinder head gasket	

ANZUGSDREHMOMENTE		Tightening Torques	
BUNDMÜTERN AM ZYLINDERFUSS	M 8	29 Nm	collar nuts cylinder bottom
ZYLINDERKOPFSCHRAUBEN	M 7	18 Nm	cylinder head bolts
BUNDMÜTTER-SCHWUNG	M 12x1	54-59 Nm	flywheel collar nut
MÜTTER FÜR PRIMÄRRAD	M 14x1,5	74-78 Nm	nut for primary sprocket
SECHSKANTSCHRAUBE	M 10	74-78 Nm	bolt for inner clutch hub
KUPPLUNGSMITNEHMER			
MOTORGEHÄUSE- UND DECKELSCHRAUBEN	M 6	8 Nm	crank case and cover bolts
MOTORBEFESTIGUNGS- SCHRAUBE	M 8	35 Nm	engine mounting bolts
SCHWINGARMBOLZEN	M 12	88 Nm	swing arm pivot

MOTORGEHAUSE / Engine case



BILD Fig	TEILENUMMER Part number	STK Qty	BILD Fig	TEILENUMMER Part number	STK Qty
1	490.30.000.044	1	40	490.30.001.000	1
2	490.30.000.000	1	41	490.30.025.000	1
5	510.30.026.100	1 ϕ 17	42	490.30.090.000	2 ϕ 9,8
6	500.30.026.000	1 ϕ 11,8	43	543.30.020.000	1
7	490.30.010.000	2	44	0770 160030	1 16x3
8	490.34.021.000	1	45	560.30.028.000	1 M10
9	501.33.025.000	1	46	0603 102151	1 10x15x1
10	0912 060163	1 M6x16	47	0912 060253	6 M6x25
11	0912 060453	4 M6x45	49	490.30.095.000	1
12	0912 060303	4 M6x30			
13	510.30.022.000	1	50	490.35.001.000	1
14	550.07.015.001	0,3	51	490.35.002.000	1
15	490.30.039.000	1	52	0912 060163	3 M6x16
20	490.30.051.044	1	53	0137 060000	7 B6
21	490.30.051.000	1		490.30.100.000	1
22	490.30.056.000	2		DICHTUNGSSATZ	
23	490.30.052.000	2		Gasket set	
24	490.30.053.000	2			
25	0084 040083	4 M4x8			
26	490.30.054.000	1			
27	490.30.050.000	1			
28	543.30.061.000	1			
29	0912 060203	8 M6x20			
30	490.30.002.000	1			
31	490.30.040.000	1			

KURBELTRIEB / Crankshaft, Piston

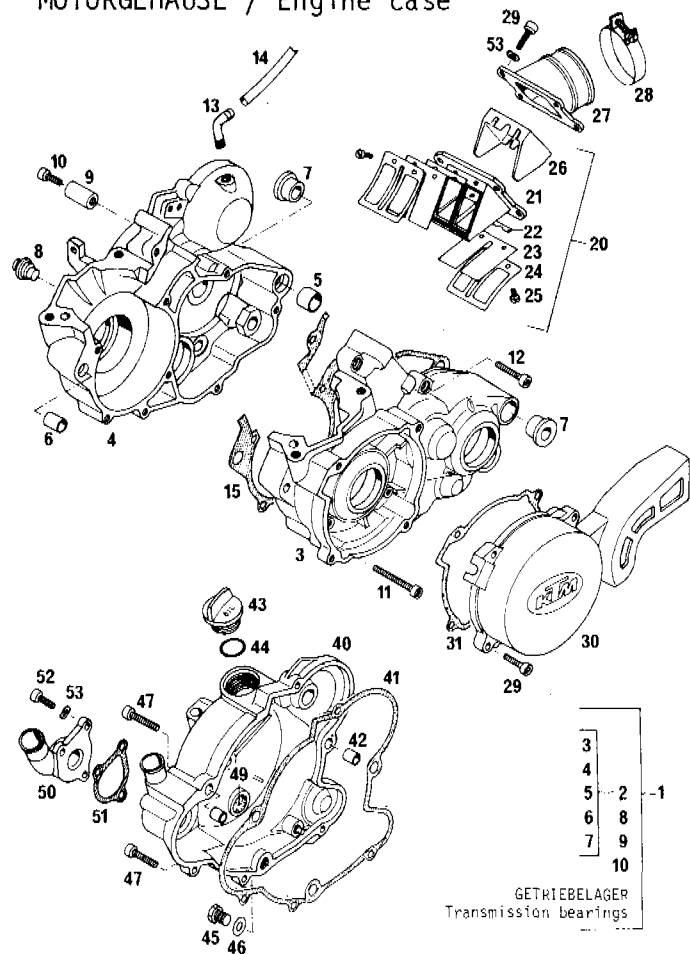

BILD Fig.	TEILENUMMER Part number	STK Qty	
1	490.30.018.000	1	46mm
2	490.30.015.044	1	
3	490.30.034.000	1	14x18x14,5
4	0888 030050	2	3x5
5	540.30.081.100	x	25x35x0,10
5	540.30.081.200	x	25x35x0,15
5	540.30.081.300	x	25x35x0,30
6	490.30.023.000	2	NJ 205
7	0760 253570	1	25x35x7
8	0760 223570	1	22x35x7
9	0137 120000	1	B12
10	490.30.021.000	1	M12x1
11	490.32.000.023	1	23-Z
12	500.30.048.000	1	14,1x30x1
13	0936 140155	1	M14x1,5
14	0760 102260	1	10x22x6
15	490.35.005.000	1	
16	0471 090010	1	A9x1
20	490.30.007.000	1	46,5mm
21	490.30.032.000	1	
22	490.30.033.000	1	
23	490.30.074.000	2	SRC14

x = NACH BEDARF / as required

ZYLINDER / cylinder

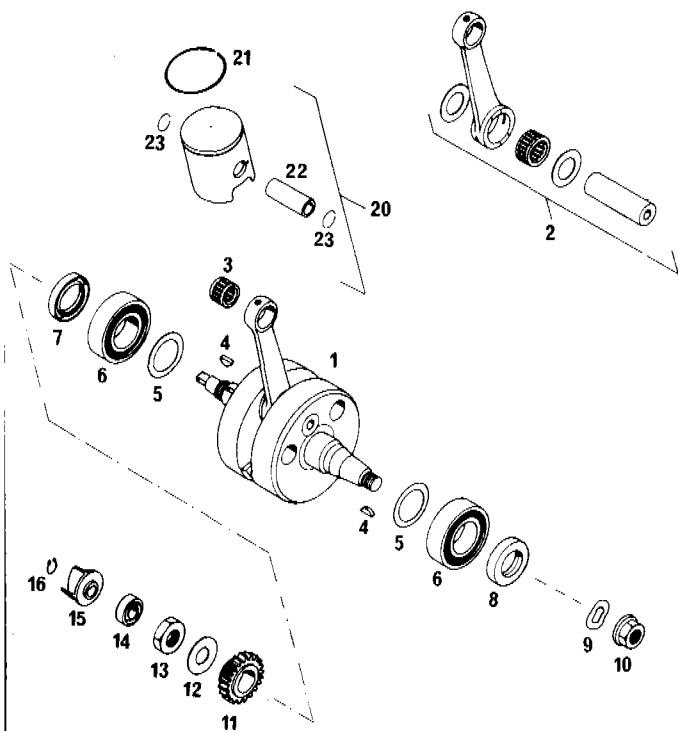

BILD TEILENUMMER STK
Fig. Part number Qty

1	490.30.005.000	1	46,5mm
2	490.30.030.005	x	0,05mm
2	490.30.030.020	x	0,20mm
2	490.30.030.030	x	0,30mm
2	490.30.030.050	x	0,50mm
2	490.30.030.100	x	1,00mm
3	0835 080253	4	M8x25
4	490.30.028.000	4	M8
5	543.35.027.000	1	
6	570.05.027.000	2	
10	490.30.006.000	1	
11	490.30.036.000	1	
13	490.30.079.000	5	M7x34,5
14	0125 070003	5	A7,4
15	500.30.680.000	5	CU7,2x12x0,2

x = NACH BEDARF / as required

VERGASER / Carburettor

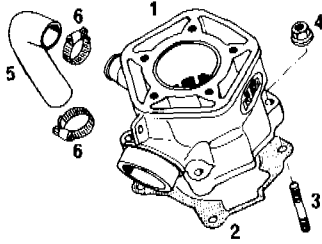
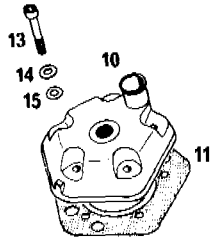

BILD TEILENUMMER STK
Fig Part number Qty

0	490.31.101.044	1	DELL'ORTO PHSB35MS
1	490.31.135.000	1	NR.40
2	490.31.134.000	1	K36
3	490.31.121....*	1	
4	490.31.122.000	1	NR.1
5	570.31.523....*	1	
6	151.31.123.0...*	1	
7	490.31.151.0...*	1	
8	572.31.120.300	1	300
9	490.31.109.000	2	9794 gr.3
10	490.31.119.000	1	
11	490.31.116.000	1	
12	520.31.138.000	1	
13	570.31.525.000	1	M6x0,75
14	490.31.227.000	1	
15	490.31.128.000	1	1,5x41x44
16	490.31.127.000	1	
17	490.31.131.000	1	
18	490.31.130.000	1	1,25x230
19	0799 025055	1	RS2,5x5,5
20	0963 045103	1	M4,5x10
21	490.31.149.000	1	
22	490.31.117.000	1	M7x0,75
23	570.31.515.000	1	
24	490.31.106.000	1	
26	490.31.112.000	1	

BILD TEILENUMMER STK
Fig Part number Qty

27	0603 082121	1	8x12x1
28	490.31.113.000	1	M8
29	490.31.108.000	1	2x27
30	490.31.174.000	1	
31	490.31.110.000	1	
32	490.31.111.000	1	
33	0127 050003	3	B5
34	0084 050203	3	M5x20
35	0603 182415	1	18x24x1,5
37	490.31.112.000	1	
36	490.31.114.000	1	M18x1
95	501.31.137.000	2	
96	830.13.096.000	2	
99	490.31.199.000	1	

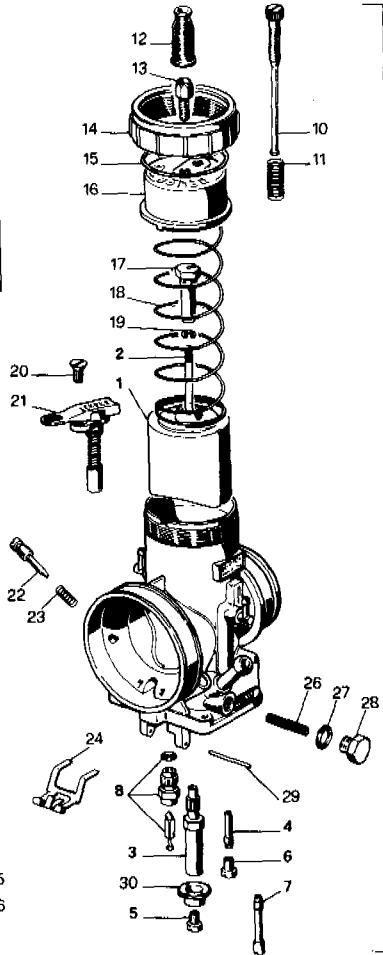
* AUFGESTEMPELTE NUMMER (GRÖSSE)
ANGEBEN!

Please quote printed number (size)!

KICKSTARTER / Kickstarter

BILD TEILENUMMER STK
Fig Part number Qty



BILD Fig	TEILENUMMER Part number	STK Qty
1	490.33.026.000	1
2	490.33.020.000	1
3	490.33.022.000	1 29-Z
4	490.33.024.000	1 18-Z
5	490.33.021.000	1
6	490.33.027.000	1
7	0991 060203	2 M6x20
8	490.33.023.000	1
9	490.33.031.000	1 14,3x20x1
10	490.33.028.000	1
20	490.33.036.044	1
21	0760 142460	1 14x24x6
22	0984 060180	1 M6x18
23	0797 060003	1 J6

GETRIEBE I / Transmission I

BILD TEILENUMMER STK
Fig Part number Qty

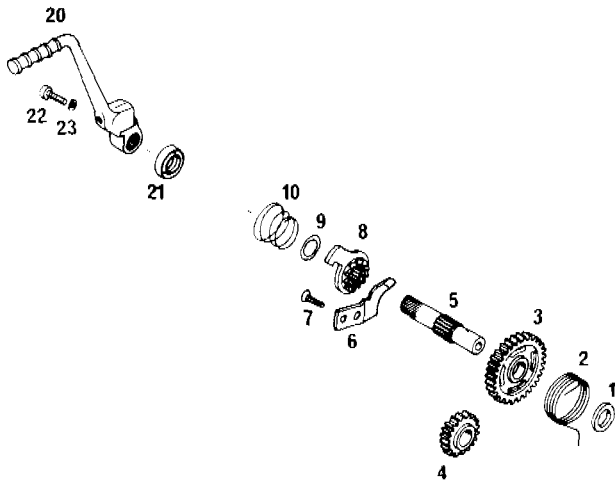

BILD Fig	TEILENUMMER Part number	STK Qty
1	490.33.011.000	1 13-Z
2	490.33.010.000	1 16-Z
3	490.33.008.000	1 18/21-Z
5	490.33.007.000	1 23-Z
6	490.33.009.000	1 24-Z
7	490.33.090.000	2 WA17x2
8	490.33.013.000	1 12,1x25x1
9	490.33.097.000	1 12x12
10	0625 982030	1 98203

GETRIEBE II / Transmission II

BILD TEILENUMMER STK
Fig Part number Qty

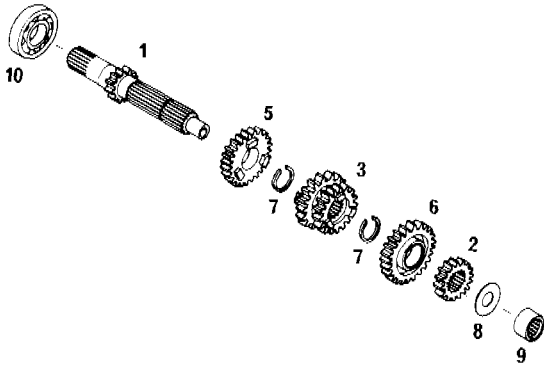

BILD Fig	TEILENUMMER Part number	STK Qty
1	490.33.001.000	1 37-Z
2	490.33.006.000	1 34-Z
3	490.33.003.000	1 31-Z
4	490.33.004.000	1 30-Z
5	490.33.002.000	1 28-Z
6	490.33.005.000	1 26-Z
7	490.33.012.000	1
8	490.33.029.013	x 13-Z
8	490.33.029.014	1 14-Z 1/2x5/16"
8	490.33.029.015	x 15-Z
9	490.33.091.000	4 AS20x1,75
10	490.33.013.000	1 12,1x25x1
11	490.33.097.000	1 12x12
12	0625 060040	1 6004
13	0760 263570	1 26x35x7
14	490.33.092.000	1 19,5x1,5
15	490.33.017.000	1 20x26x11
16	544.03.135.000	1

x = NACH BEDARF / as required

SCHALTUNG / Shifting Mechanism

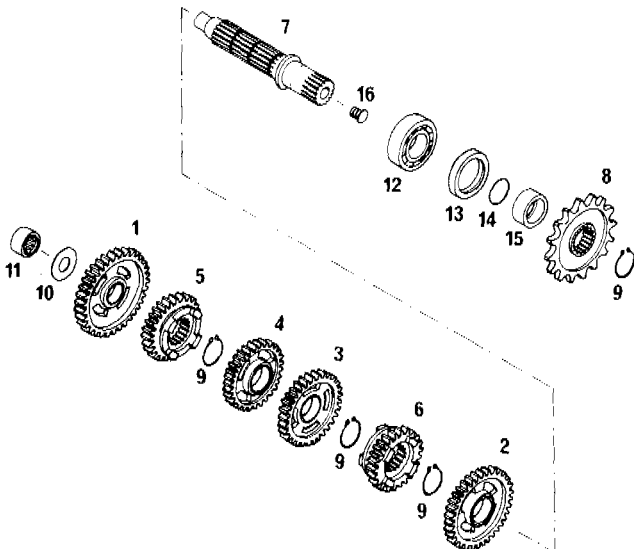

BILD Fig	TEILENUMMER Part number	STK Qty
1	490.34.005.100	1
2	490.34.007.000	1
3	490.34.008.000	1
4	490.34.009.000	1
5	490.34.013.000	1
6	490.34.014.000	1
10	490.34.022.000	1
11	0760 122050	2 12x20x5
20	490.34.012.000	1
21	501.34.026.000	1 30x38x7,5
22	490.34.015.000	1
23	0991 060253	1 M6x25
24	490.34.023.000	1
25	490.34.024.044	1
26	0471 100010	1 A10x1
30	490.34.004.000	1
31	490.34.002.100	2
32	490.34.003.000	1
33	490.34.001.100	1

KÜHLSYSTEM / Cooling system

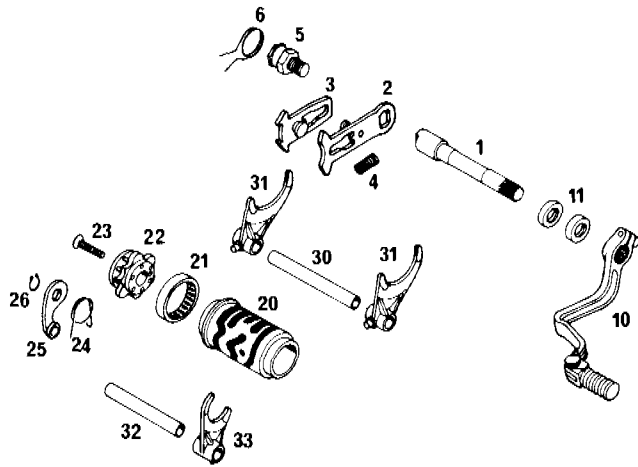

BILD Fig	TEILENUMMER part number	STK Qty
1	490.35.007.000	1 (4.5010)
2	490.35.016.000	1
3	543.35.030.100	1
4	543.35.034.000	1
5	500.35.025.001	0,25
6	543.35.027.000	1
7	100.01.020.000	4
8	550.07.016.001	0,4
9	543.35.031.000	3
10	0021 060003	6
11	0797 060003	6
12	0934 060003	6
13	0983 480163	3
14	400.06.006.000	1
15	310.05.142.000	3

ZÜNDANLAGE / Ignition system

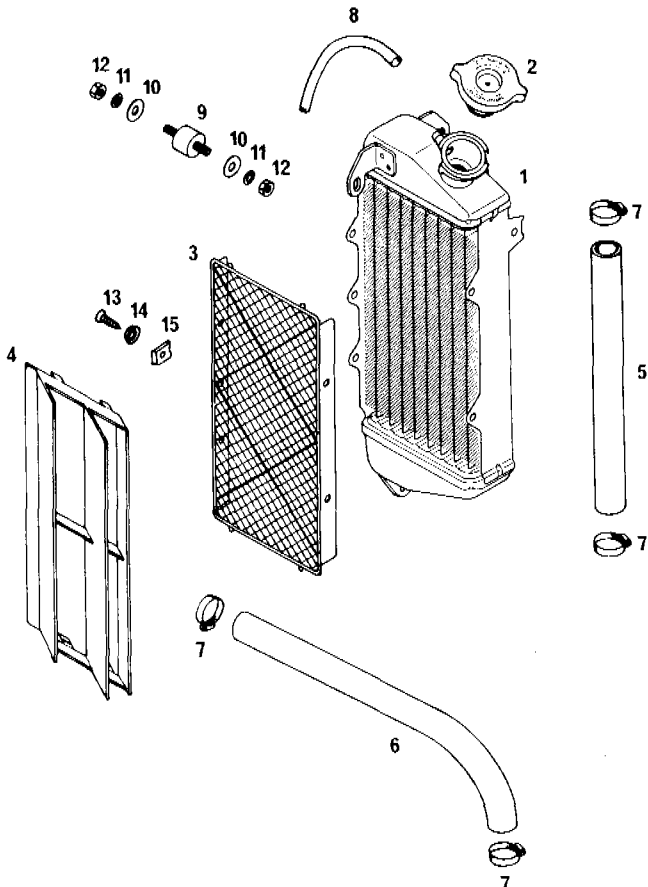

BILD Fig	TEILENUMMER Part number	STK Qty	
1	490.31.002.000	1	MOTOPLAT 0619 303
2	0085 050203	3	M5x20
3	0137 050003	3	
4	0125 050003	3	
5	490.31.031.052	1	
6	543.11.058.100	2	
10	490.31.031.000	1	MOTOPLAT 9635401
11	490.31.031.051	1	
12	510.31.011.000	1	
13	510.31.005.000	1	
14	100.11.072.100	1	
15	440.11.076.180	x	
16	490.31.013.000	1	
17	490.31.113.000	1	
20	510.31.006.200	1	
21	510.31.010.100	1	
22	560.31.093.370	1	W07CS (370S2S)
30	0933 060163	4	
31	0125 060003	2	
32	0021 060003	2	
33	0985 060003	4	

x = NACH BEDARF
as required

KUPPLUNG / Clutch

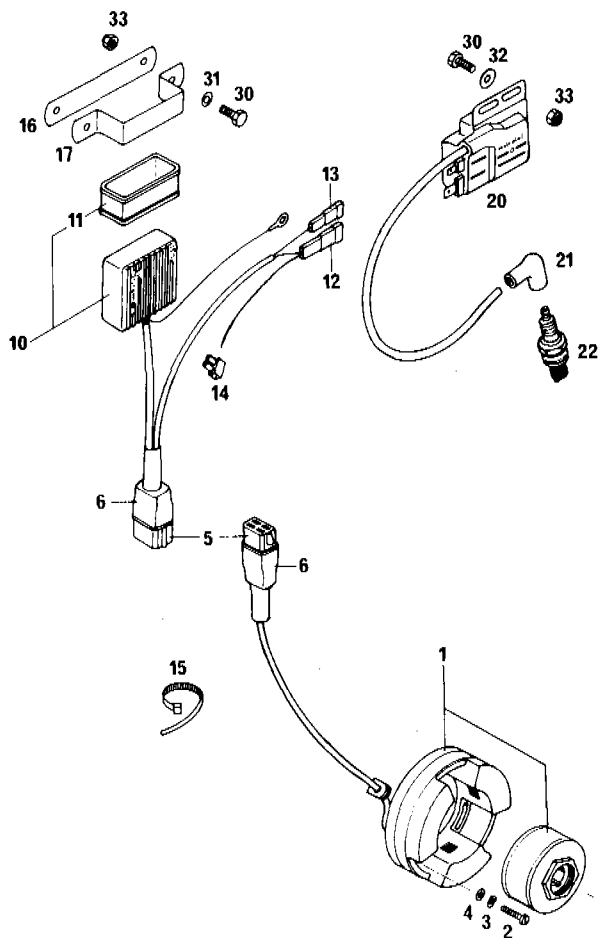

BILD Fig	TEILENUMMER Part number	STK Qty	
1	490.32.001.075	1	75-Z
2	490.32.001.000	1	
3	0338 050095	6	A5x9,5
4	490.32.012.000	2	17,2x30x1,5
5	490.32.095.000	1	17x21x17,2
6	490.32.096.000	1	21x25x17
7	490.32.003.000	1	
8	490.32.004.000	7	
9	490.32.105.000	6	
10	490.32.002.000	1	
11	490.32.011.000	1	
12	490.32.006.000	6	
13	490.32.007.000	1	
14	0991 060203	6	M6x20
20	0799 050000	1	RS5
21	490.32.008.000	1	
22	490.32.010.050	2	AS 0619
23	490.32.010.000	1	AXK 0619
24	490.32.009.000	1	
30	490.32.013.000	1	
31	0770 082020	1	8,2x2
32	490.32.015.000	1	
33	0984 060163	1	M6x16
34	501.34.027.000	1	M6x20



1	490.12.001.000	
3	490.12.003.000	
4	490.12.004.000	
5	490.12.005.010	∅10
6	490.12.005.012	∅12
7	490.12.005.025	∅25
8	510.12.009.000	M27x1
9	510.12.011.000	
10	501.12.013.000	
11	510.12.014.000	
12	510.12.016.000	
13	151.12.017.000	
14	151.12.018.000	
15	501.12.030.000	
16	SELBSTGEFERTIGT self-made	
17	SELBSTGEFERTIGT self-made	
18	6.899.786	LOCTITE 242 BLAU/blue

MOTOR TYP 490
Engine Type 490 '86
80cc - MX

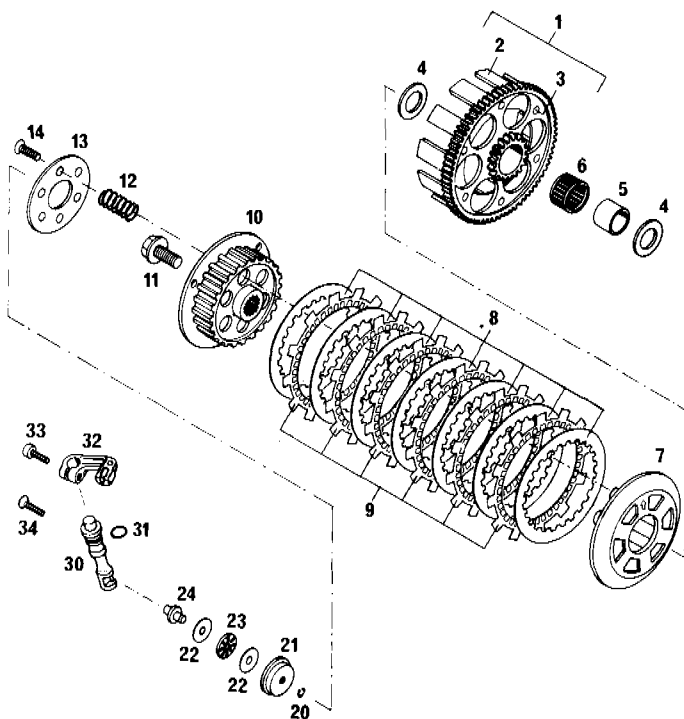
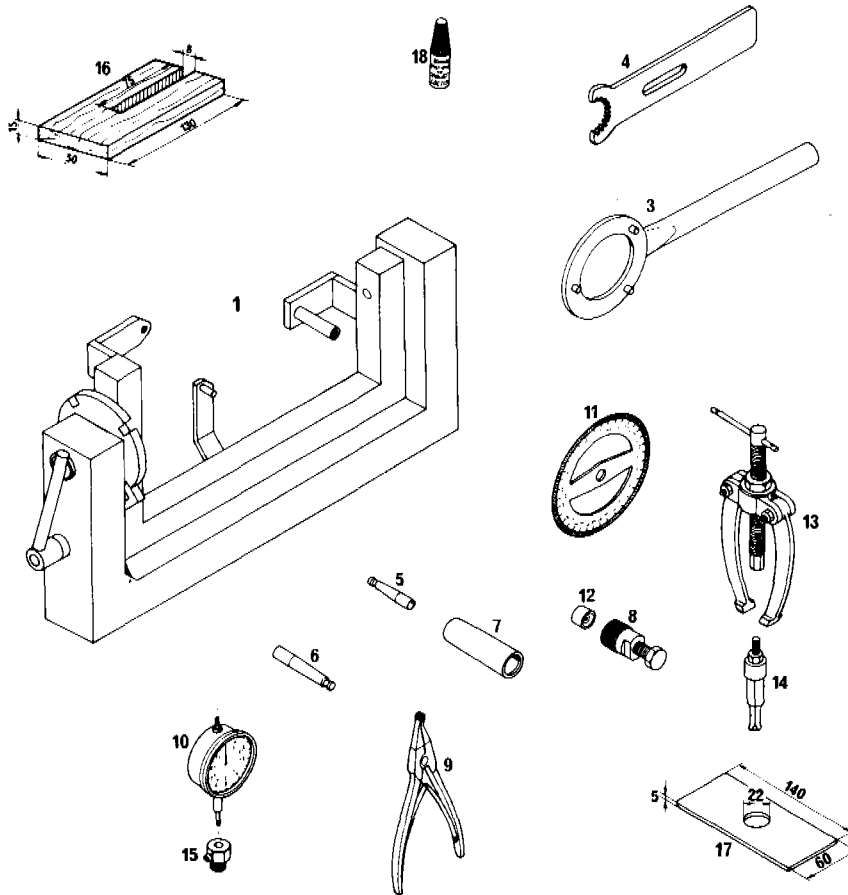
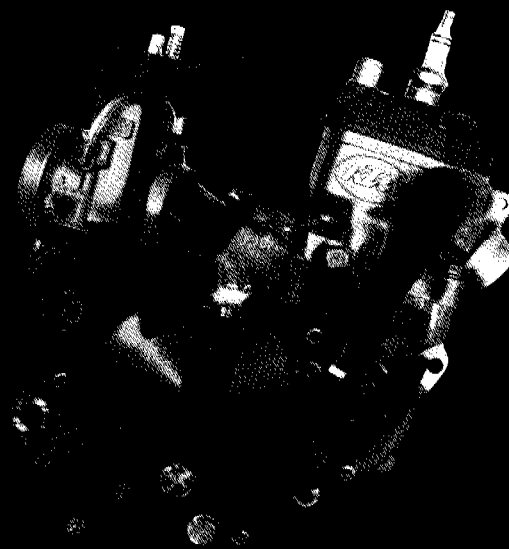

KTM Motor-Fahrzeugbau KG
Erich Trunkenpolz
A-5230 Mattighofen - Austria